

Numeracy Across the Curriculum

Form Time Numeracy Puzzle

Mathematical anagrams.

An anagram is a word or phrase made up of the letters of another word.

These are all made up from maths words.

Can you work them out?



SITE TEAM

MOLERKITE

UMS

LIB LION

BART SUCTION

A CROFT

Numeracy Across the Curriculum

Form Time Numeracy Puzzle

If a number in one of the balloons is included in the answers to the three problems below then that balloon will fly away.

Which balloon is left?

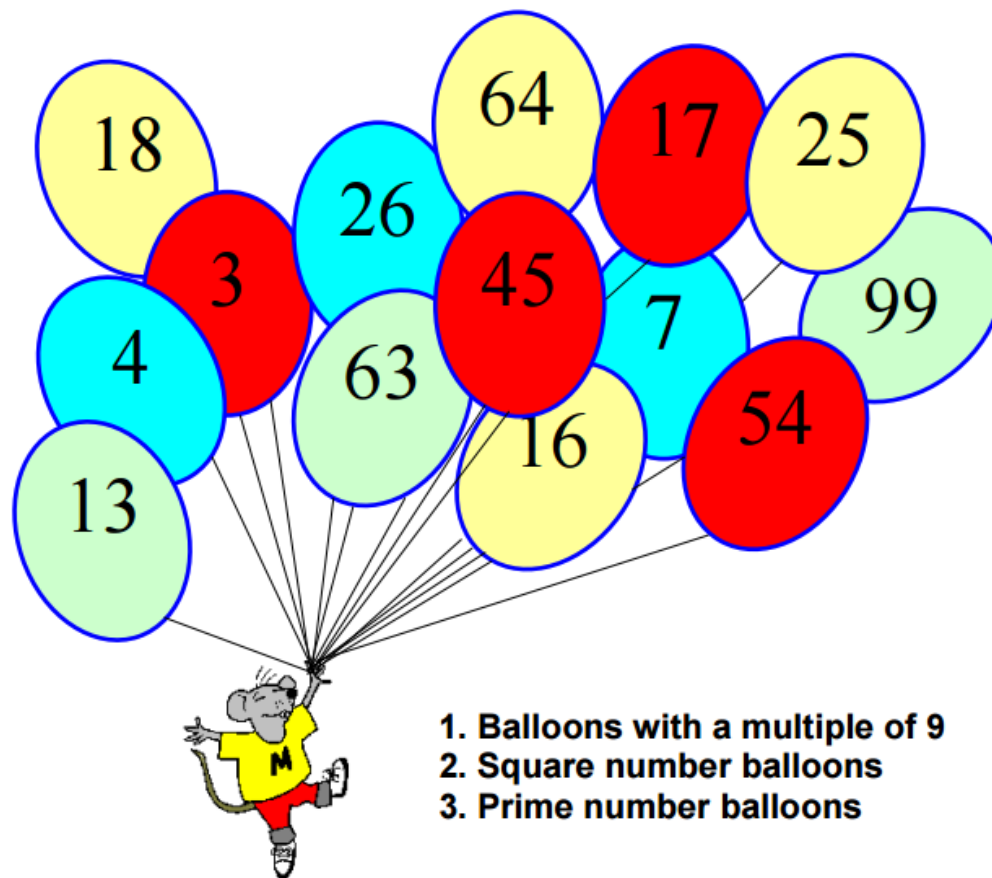

1. Balloons with a multiple of 9
2. Square number balloons
3. Prime number balloons

Numeracy Across the Curriculum

Form Time Numeracy Puzzle

Susie the snake has up to 20 eggs.

She counted her eggs in fours, she had 3 left over.

She counted her eggs in fives, she had 4 left over.

How many eggs has Susie got?

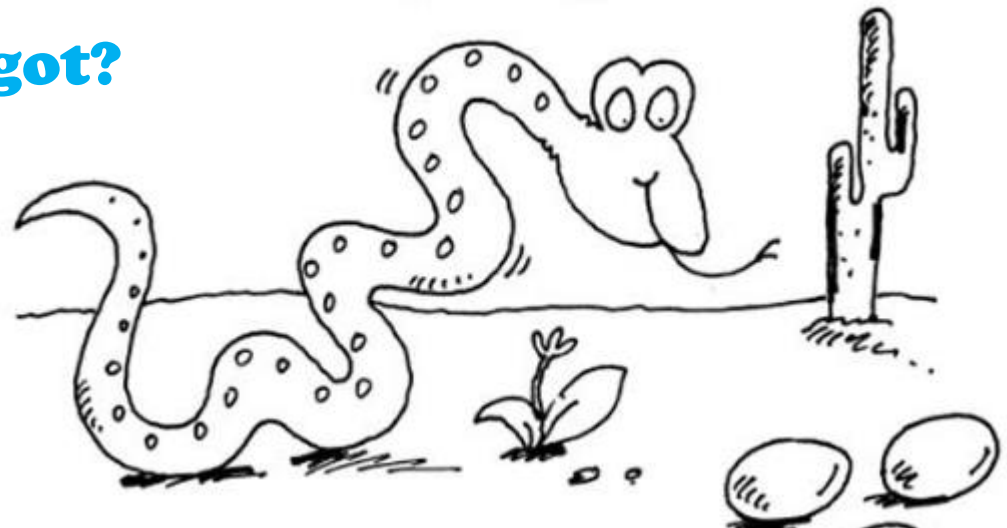

Numeracy Across the Curriculum

Form Time Numeracy Puzzle

Using any whole numbers as many times as you like make each line of the rectangle add up to 20.

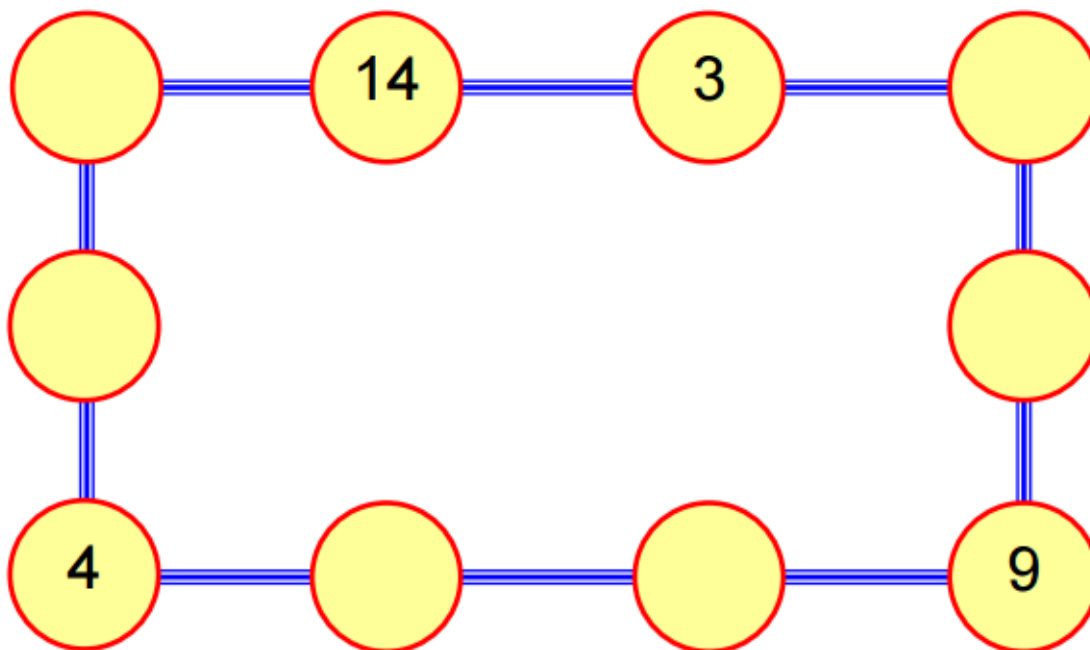

Numeracy Across the Curriculum

Form Time Numeracy Puzzle



Find a number with its letters in alphabetical order.

Example: "five" has "fiv" in alphabetical order, but not "e".

Numeracy Across the Curriculum

Form Time Numeracy Puzzle

A magic square which adds up to exactly nothing. Put these numbers into the square above so that each row across, down and diagonally adds up to zero.

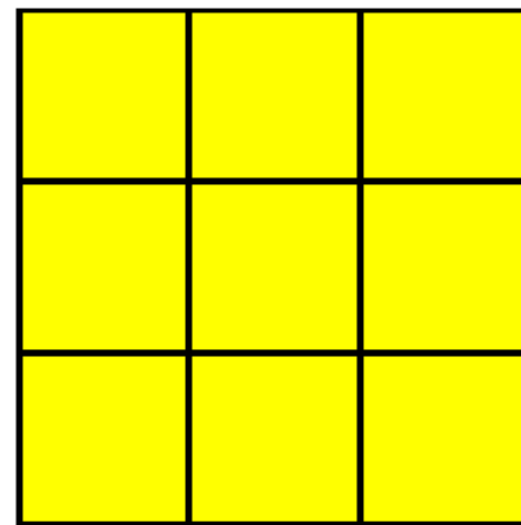
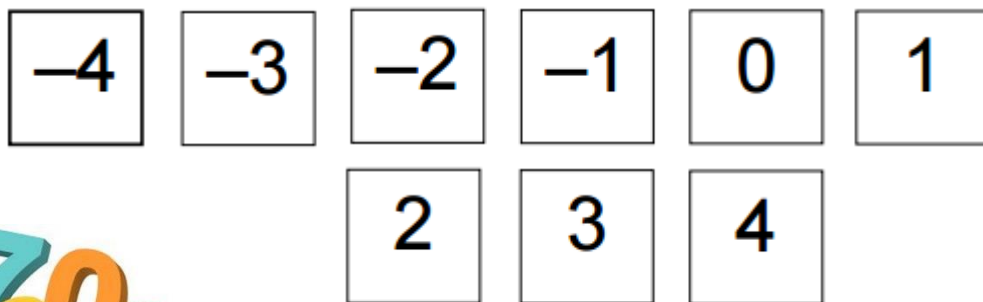

Numeracy Across the Curriculum

Form Time Numeracy Puzzle

Draw 3 lines across the circle
(from edge to edge)
to divide the circle into several regions
that add up to the same total.

Lines can cross each other, but not numbers.
No region can be empty.

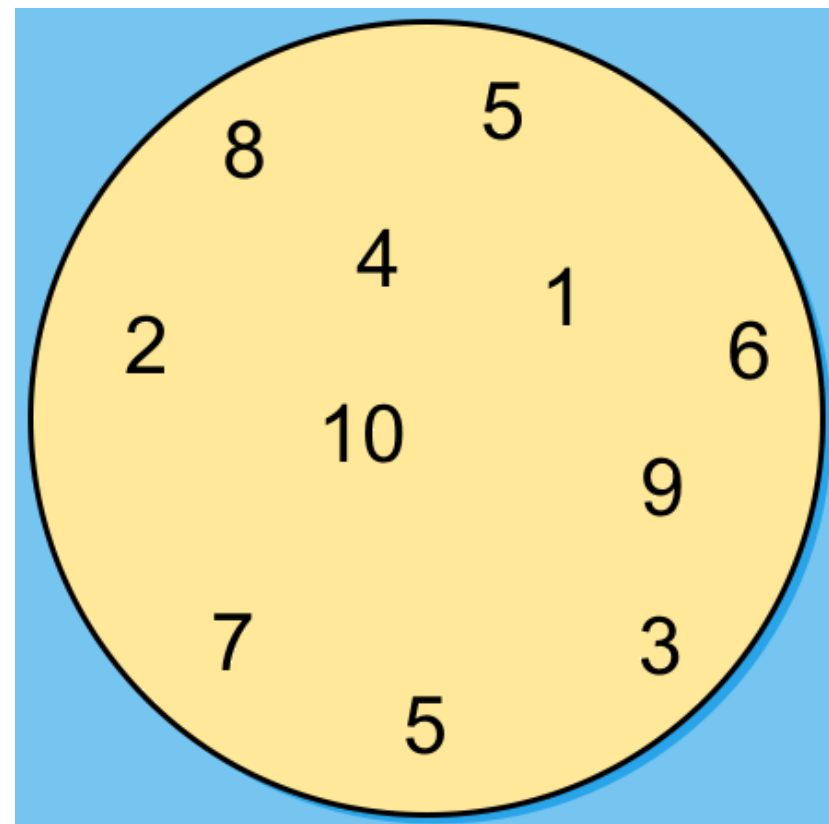

Numeracy Across the Curriculum

Form Time Numeracy Puzzle

Chico's cards are all different.

There is a number from 1 to 8 on each card.

Chico has chosen four cards that add up to 20.

What are they? There are seven different possibilities.

Try to find them all.



Numeracy Across the Curriculum

Form Time Numeracy Puzzle

*Can you put the numbers
1 to 8 in each of the squares
so that each side adds up
to the middle number?*

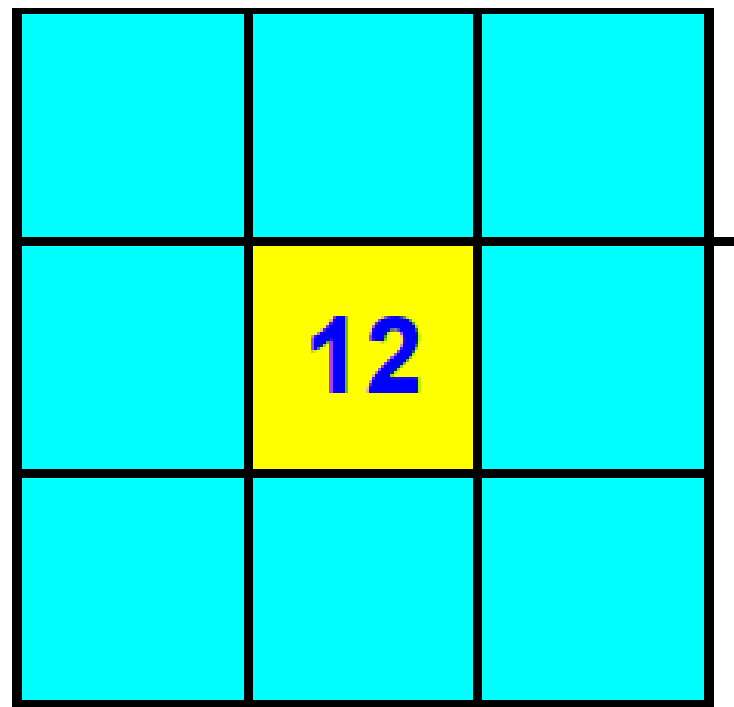

Numeracy Across the Curriculum

Form Time Numeracy Puzzle

B	R	A	V	E
	E	B	R	
		V		B
	B	R		
		E	B	

Only for the brave, this one!

This square has eleven letters missing, which you have to replace:

Every row, column AND the main diagonals contain all the letters in the word "BRAVE".

Numeracy Across the Curriculum

Form Time Numeracy Puzzle

These coins are commonly used in Britain today.

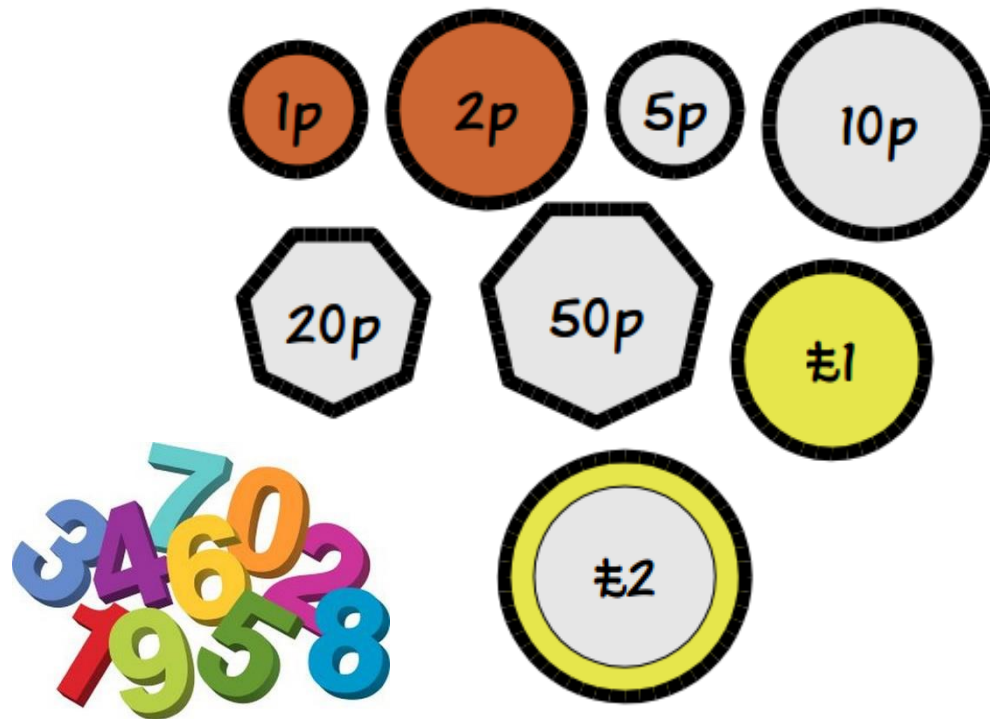

What is the fewest number of coins you need to make:

- a) 83p
- b) £1.34
- c) £5.27

Numeracy Across the Curriculum

Form Time Numeracy Puzzle

Put the numbers 1, 2, 3, 4, 5, 6 and 7 in the circles so that each straight line of three numbers adds up to the same total.

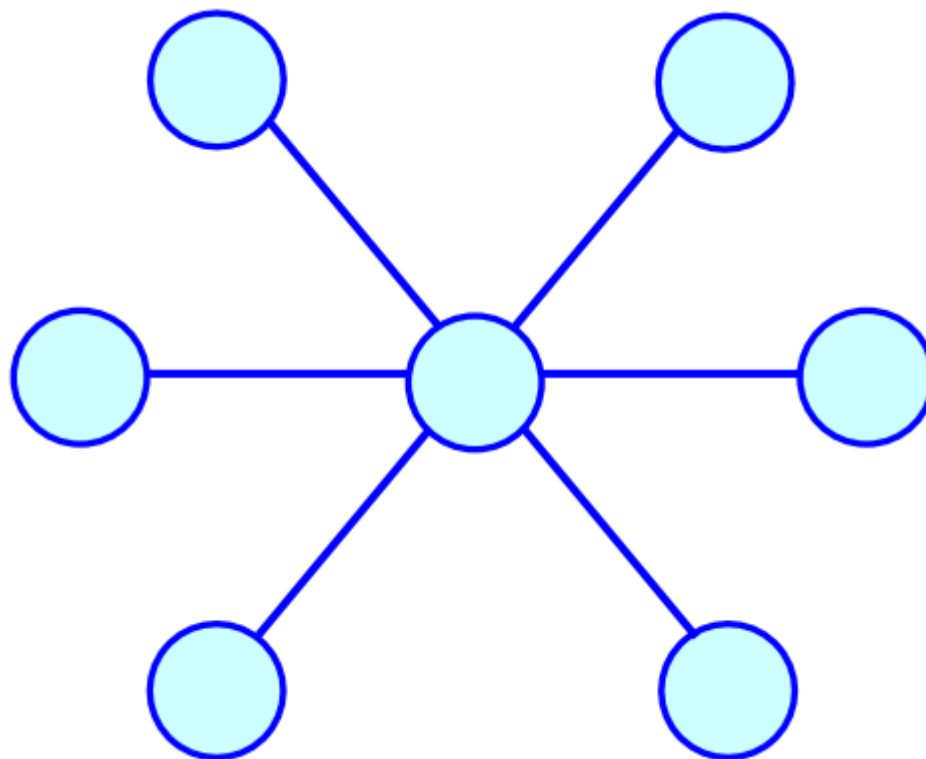

Numeracy Across the Curriculum

Form Time Numeracy Puzzle

Put in each of the numbers from 1-9 (once each only) to make these sums true.

(Hint: remember the order of operations – do any multiplications before the addition or subtraction.)

	X		+		11
-		-		+	
	+		+		15
X		-		-	
	-		X		-47
-54		-4		-4	



Numeracy Across the Curriculum

Form Time Numeracy Puzzle

Use only these numbers: 26, 40, 56, 71, 89

Complete these calculations:

$$[\quad] + [\quad] + [\quad] = 249$$

$$[\quad] + [\quad] + [\quad] = 183$$

$$[\quad] + [\quad] + [\quad] = 231$$

$$[\quad] + [\quad] + [\quad] = 141$$

$$[\quad] + [\quad] + [\quad] = 218$$

Numbers can be used more than once in each calculation.



Numeracy Across the Curriculum

Form Time Numeracy Puzzle

What is the four digit number with no zeros,
in which the first digit is five times the last,
the second is four more than the first
and the three times the third,
and the third is two more than the last
and two less than the first?



Numeracy Across the Curriculum

Form Time Numeracy Puzzle

I have ten boxes which I want to pack into crates. Each crate can carry a maximum of 25 kg.

But I only have three crates, and the total weight of the boxes is 75kg:

15 kg, 13kg, 11 kg, 10 kg, 9 kg, 8 kg, 4 kg, 2 kg, 2kg, 1 kg

How can I pack the boxes into the crates?



Numeracy Across the Curriculum

Form Time Numeracy Puzzle

Mathematical anagrams.

An anagram is a word or phrase made up of the letters of another word.

These are all made up from maths words.

Can you work them out?



ANGEL

RENUMB

CAR

DOD

CAGEDON

TRAIN LEG

Numeracy Across the Curriculum

Form Time Numeracy Puzzle

Fill in the puzzle so that
every row across,
every column down
and every 2 by 2 box
contains the numbers 1 to 4.



3			
			1
4		1	
	2		

Numeracy Across the Curriculum

Form Time Numeracy Puzzle

Copy this diagram.

Can you draw 4 straight lines
that go through all the dots
without lifting your pencil off
the paper?



Numeracy Across the Curriculum

Form Time Numeracy Puzzle

*Can you put the numbers
1 to 8 in each of the squares
so that each side adds up
to the middle number?*

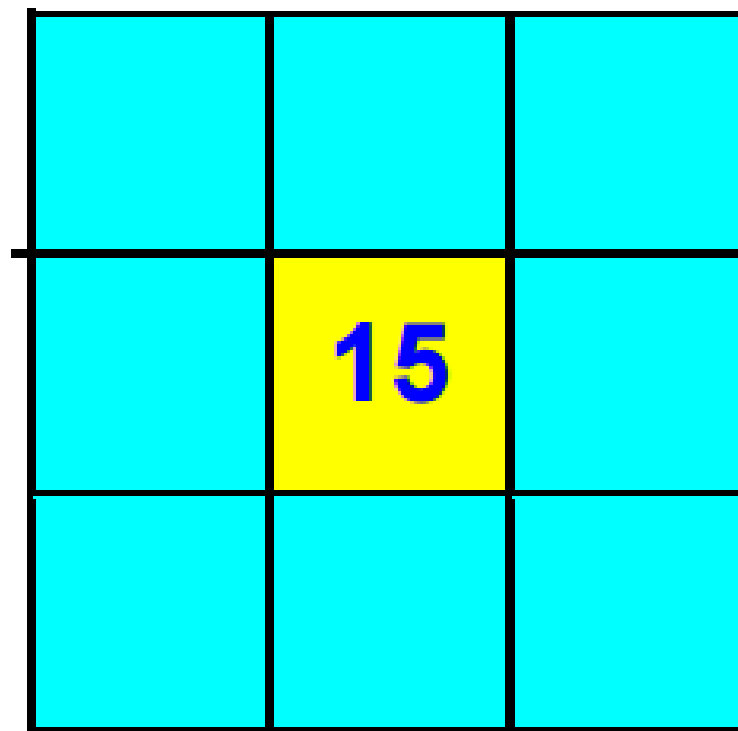

Numeracy Across the Curriculum

Form Time Numeracy Puzzle

In each of the squares of the grid, write one of the letters P, Q, R and S so that adjacent (whether connected by an edge or a corner) do not contain the same letter.

P	Q			
R	S			
		Q		
Q				

